

1kw and 150 watt HMI Fresnel

Compact circular shaped fresnel, with soft edged variable beam from a spot of 13 degrees to a wide angle flood of 64 degrees. Available for 1000 watt tungsten halogen or 150 watt HMI single ended lamps. Constructed from aluminium extrusion, with cast aluminium ends for lightness and strength. A handle is conveniently placed at the back and the front features a hinged door for ease of access to lamp and cleaning of interior. Colour frame is securely retained by a spring loaded pin. Available in either black or silver finish and supplied with 1 metre of silicon 3 core cable. Barn door can be specified as an option.

PRODUCT CODE	DESCRIPTION	WT kgs
D1100	Fresnel GX 9.5 base Black	4.51
D1100S	Fresnel GX 9.5 base Silver	4.51
D1103	Fresnel 150w HTI Black	7.5
D1103S	Fresnel 150w HTI Silver	7.5
D1101	Barn door	0.56
D1102	Colour frame	-
G6620	Fresnel lens	-
LAMPS		
-	T11 120 V 1000 W GX 9.5	-
-	T11 240 V 1000 W GX 9.5	-
-	T29 240 V 1200 W GX 9.5	-
-	HMI 150 watt lamp	-

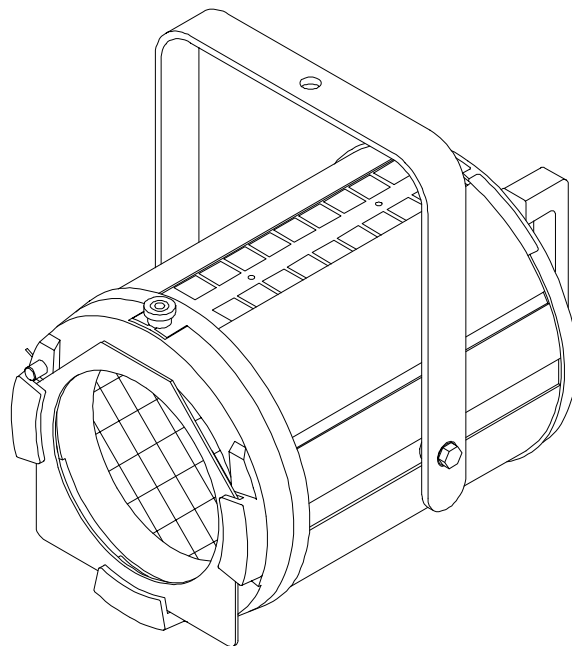

PHOTOMETRIC DATA

T11 240 V 1000 W LAMP

All measurements are in Metres

SPOT

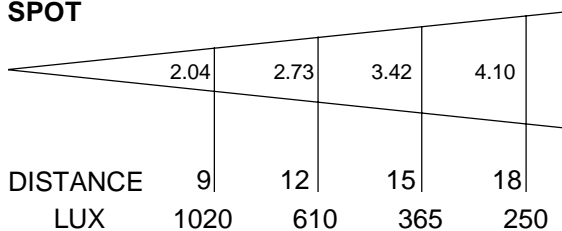

FLOOD

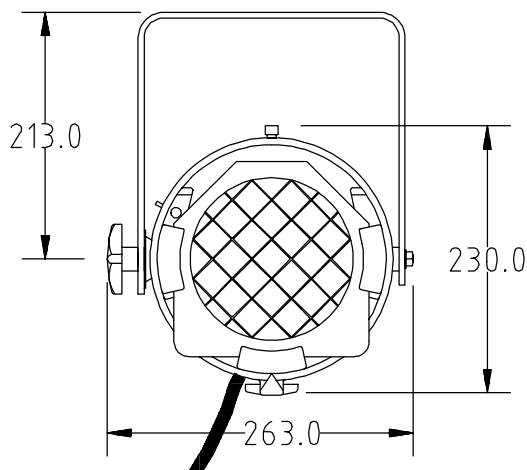
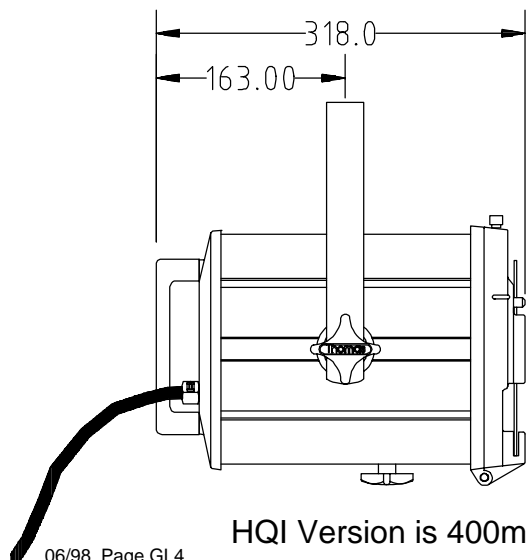

HQI Version is 400mm Long